

## Cleaner System

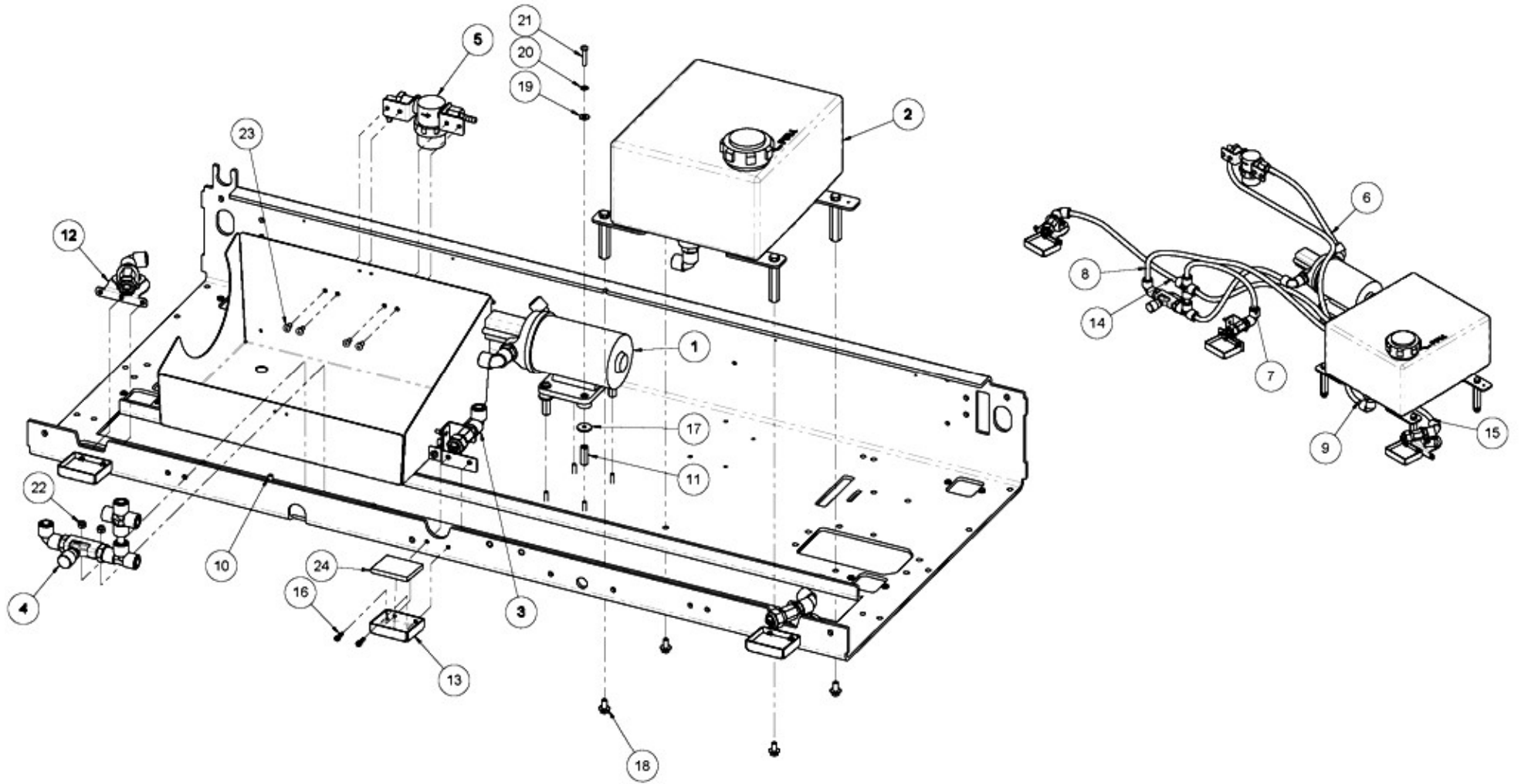

### Cleaner System

	NUMBER	DESCRIPTION
1	294-116-049	CLEANER PUMP & FITTINGS, 110V
	294-116-048	CLEANER PUMP & FITTINGS, 220V
2	294-116-105	CLEANER TANK & BRACKET ASM
3	294-116-113	SWIVEL NOZZLE ASM
4	294-116-151	FLOW CONTROL NOZZLE ASM
5	294-115-673	FILTER ASM
6	294-116-152	TYGOTHANE TUBE, 9 IN
7	294-116-153	TYGOTHANE TUBE, 12 IN
8	294-116-154	TYGOTHANE TUBE, 35 IN
9	294-116-155	TYGOTHANE TUBE, 37 IN
10	294-115-733	TUBE SUPPORT
11	722-502-091	SPACER, FEMALE HEX, 10-32 X 3/8 X 1
12	294-116-234	SIDE NOZZLE ASM

	NUMBER	DESCRIPTION
13	294-115-650	DRIP TRAY
14	294-116-238	TYGOTHANE TUBE, 16 IN
15	294-116-239	TYGOTHANE TUBE, 31 IN
16	810-240-088	SCREW, SOCKET-HEAD CAP 10-32 X 0.50, STAINLESS STEEL
17	7150-019075-009	WASHER, FLAT, 3/16 X 3/4 X 3/32, ALUMINUM
18	801-749-081	SCREW, FLANGE HEAD HEX, 1/4-20 X 1/2
19	01-030	WASHER, FLAT, #10 SAE, ZINC
20	01-033	WASHER, EXTERNAL TOOTH LOCK, #10 ANSI, ZINC
21	01-024	SCREW, PAN-HEAD PHILLIPS MACHINE 10-32 X 1.00, ZINC
22	832-040-008	NUT, NYLON LOCK, 10-32
23	01-019	SCREW, PAN-HEAD PHILLIPS MACHINE 10-32 X 0.38 ZINC
24	294-115-554	DRIP TRAY FOAM

### Cleaner Pump Assembly

	NUMBER	DESCRIPTION
1a	02-206	CLEANER PUMP, 110V
1b	294-115-287	CLEANER PUMP, 220V
2	294-115-072	STEM ADAPTER, 3/8 MPT X 3/8
3	294-115-073	UNION ELBOW, 3/8 X 3/8
4	294-115-729	CLEANER PUMP ASM, 110V (INC. 1a, 5, & 6)
	294-115-730	CLEANER PUMP ASM, 220V (INC. 1b, 5, & 6)
5	746-013-498	CONNECTOR, 2 POSITION
6	760-019-223	CRIMP TERMINAL, FEMALE, 14-20 AWG

