

Oil Tank Assembly

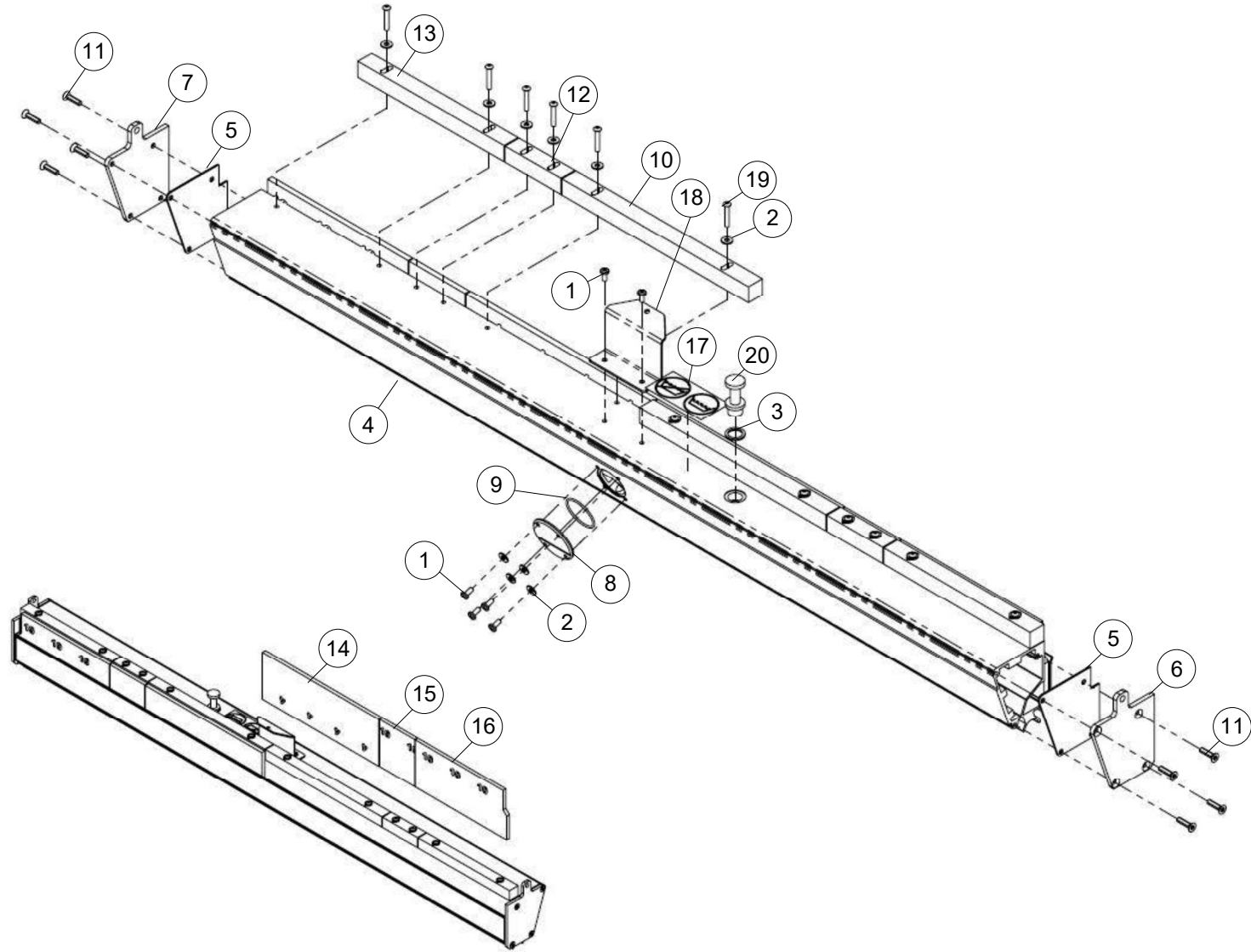

Oil Tank Assembly

	NUMBER	DESCRIPTION
1	01-009	SCREW, PAN HEAD, 8-32 X 3/8
2	01-109	WASHER, FLAT, #8
3	04-093	RUBBER DIPSTICK SEAL
4	294-115-508	OIL TANK
5	294-115-509	OIL TANK GASKET
6	294-115-510	OIL TANK CAP, RIGHT HAND
7	294-115-511	OIL TANK CAP, LEFT HAND
8	294-115-512	SIGHT GLASS DISK
9	294-115-513	SIGHT GLASS O-RING
10	294-115-515	ADJUSTMENT BAR, 10-INCH

	NUMBER	DESCRIPTION
11	294-115-516	SCREW, THREAD FORMING, 10-24 X 3/4
12	294-115-530	ADJUSTMENT BAR, 3-INCH
13	294-115-531	ADJUSTMENT BAR, 7-INCH
14	294-115-551	WICK, FOAM, SHO
15	294-115-553	WICK, FOAM, LO
16	294-115-665	WICK, FOAM, MLO
17	294-115-667	OVERFILL STICKER
18	294-116-067	OIL TANK PULL BRACKET
19	808-533-167	SCREW, BUTTON HEAD, 8-32 X 1
20	A-0330	OIL TANK PLUG

Replacement Wicking Foams

NUMBER	OIL OUTPUT	STENCIL #	LENGTH
294-115-654	SUPER LOW	13	48"
294-115-653	EXTRA LOW	12	48"
294-115-652	LOW	11	48"
294-115-482	MEDIUM LOW	10	48"
294-115-484	MEDIUM	8	48"
294-115-486	MEDIUM HIGH	6	48"
294-115-488	HIGH	5	48"
294-115-490	SUPER HIGH	4	48"