

Left Hand Buffer Mounting Assembly - 294-116-090

	NUMBER	DESCRIPTION
1	294-116-085	BUFFER PIVOT SHAFT
2	294-116-086	BUFFER PIVOT MOUNTING BLOCK
3	294-116-088	SWIVEL END BEARING
4	294-116-089	LEFT HAND BUFFER ARM
5	701-406-108	BUSHING, FLANGED, 1/2 X 5/8 X 3/4 X 1/8
6	808-849-100	SCREW, FLAT HEAD, 1/4-20 X 5/8
7	808-849-280	SCREW, FLAT HEAD, 1/4-20 X 1-3/4
8	836-549-008	NUT, HEAVY JAM, 1/4-20

**Right Hand Buffer Mounting Assembly - 294-116-093**

	NUMBER	DESCRIPTION
1	294-116-084	RIGHT HAND BUFFER ARM
2	294-116-085	BUFFER PIVOT SHAFT
3	294-116-086	BUFFER PIVOT MOUNTING BLOCK
4	294-116-091	BRUSH PULLEY
5	294-116-092	BUFFER PULLEY COLLAR
6	701-013-040	BEARING, 10 mm X 30 mm X 9 mm
7	701-406-108	BUSHING, FLANGED, 1/2 X 5/8 X 3/4 X 1/8
8	808-849-280	SCREW, FLAT HEAD, 1/4-20 X 1-3/4
9	836-549-008	NUT, HEAVY JAM, 1/4-20
10	880-110-350	SCREW, HEX SHOULDER, 10 mm X 35 mm
11	919-019-050	SNAP RING, INTERNAL, 1.319 X .050

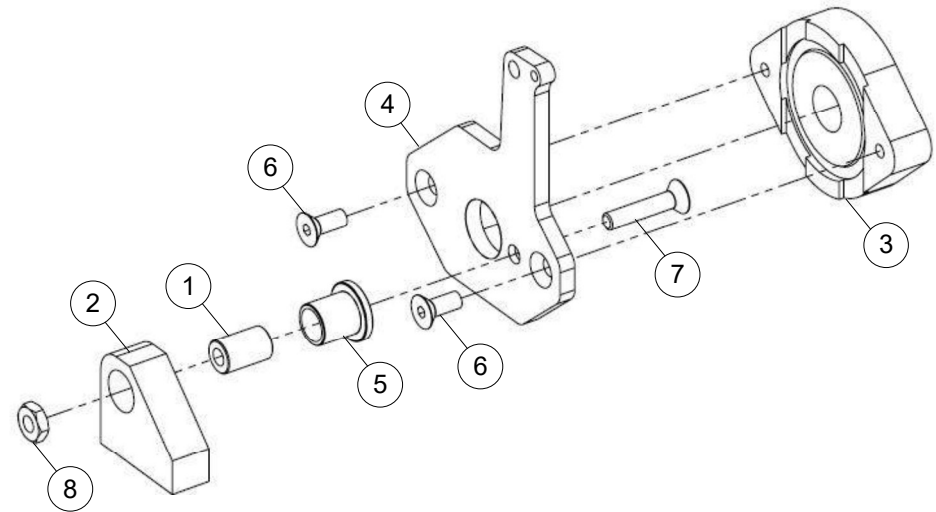