

Index No.	Part No.	Package / Order Reference	Description
1.	55-078115-009		Cluster Housing Assembly
2.	*55-078115-000		Cluster Housing
3.	55-078255-000		Switch Support 2 (Home Switch)
4.	11-052020-001		Flat Washer (5.3 mm x 12 mm x 1 mm)
5.	11-051742-001		Hex Locknut (M5)
6.	99-050181-004		Switch Holder
7.	11-052021-001		Flat Washer (4.3 mm x 12 mm x 1 mm)
8.	11-051741-001		Hex Locknut
9.	11-052354-001		Slotted Pan Head Machine Screw (M4 x 12 mm)
10.	11-054601-001		Pop Rivet
11.	99-226387-000		Cable Tie Holder
12.	55-143047-000		Assembly - Cluster Reed Switch
13.	55-078116-000		Cluster Cover
14.	55-078216-009		Cluster Gear Assembly
15.	11-053478-001		Quick Lock (Speed Nut)
16.	11-690553-000		Retainer - Push-On
17.	11-051069-001		Screw Hex Cap (M5 x 12 mm)
18.	99-268200-003		"Moving Parts" Safety Label
19.	11-052008-001		Flat Washer (10.5 mm x 20 mm x 2 mm)
20.	11-051769-001		Lock Washer (M10)
21.	11-051035-001		Screw Hex. Cap. (M6 x 16 mm)

\* Not sold separately - order index number 1.

## Switch Cluster

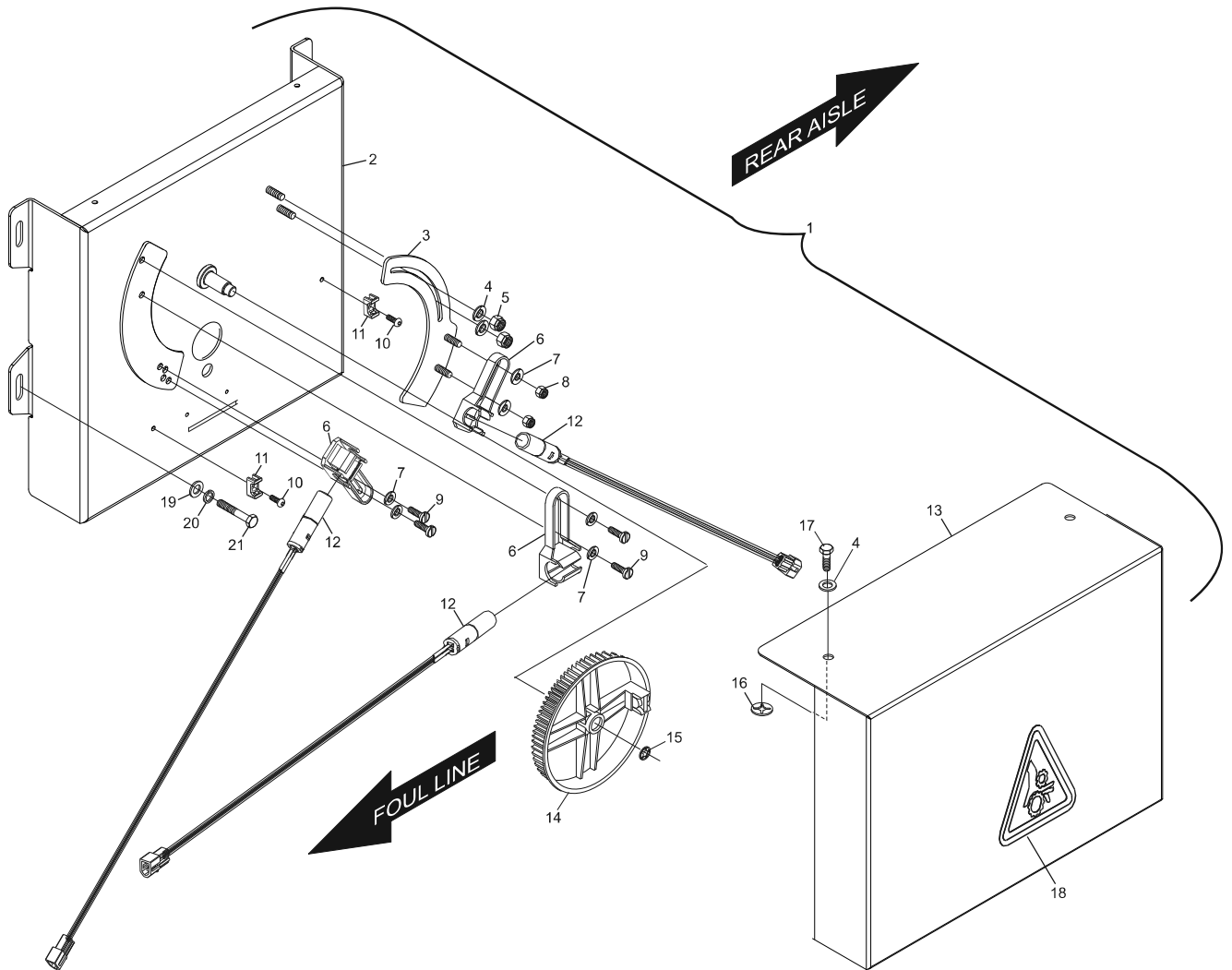

## Switch Cluster