

Buffer Motor Assembly

	NUMBER	DESCRIPTION
1	01-041	SCREW, SET, CUP POINT 1/4-20 X 1/4
2	294-002-268	BUFFER MOTOR
3	294-116-069	BUFFER MOTOR PULLEY
4	294-116-071 294-116-070	BUFFER MOTOR ASM, 110V (INC. 2,3,4, & 5) BUFFER MOTOR ASM, 220V (INC. 2,3,4, & 5)
5	294-116-079	BUFFER MOTOR PIGTAIL (INC. 4 & 5)
6	746-013-498	CONNECTOR, 2 POSITION
7	760-019-223	CRIMP TERMINAL, FEMALE, 14-20 AWG

The buffer motor must be wired for either 110V or 220V use. Remove motor endcap cover for wiring access. For both 110V and 220V operation, connect pigtail blue wire to L1 and pigtail black wire to L2 then follow the instructions below.

For 110V operation connect: the red wire to the #2 terminal and the black wire to the #4 terminal.

For 220V operation connect: the red wire to the #2 terminal, white wire to the #3 terminal, black wire to the #4 terminal, and blue to the #5 terminal.

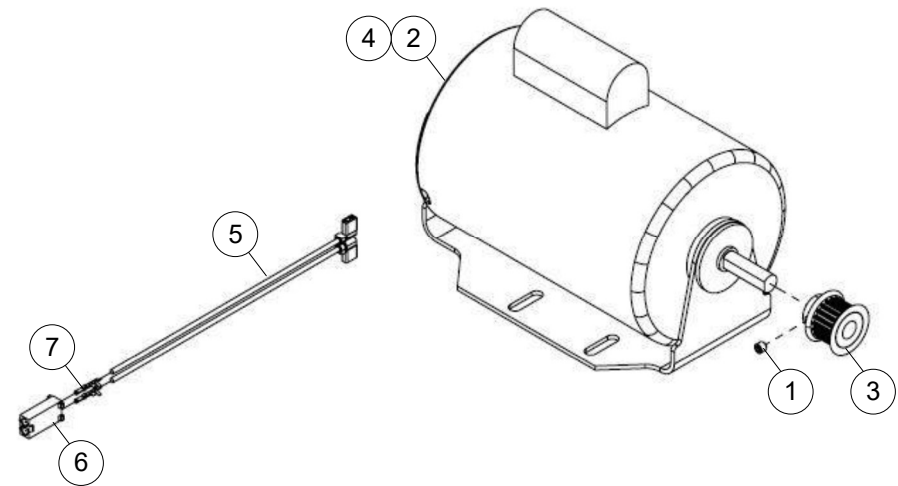

Transfer Roller Motor Assembly - 294-116-150

	NUMBER	DESCRIPTION
1	01-029	SCREW, SET, CUP POINT 10-32 X 3/16
2	294-001-006	SPROCKET, #25 CHAIN, 25T
3	294-116-023	TRANSFER MOTOR ASM (INC. 4 & 5)
4	746-013-498	CONNECTOR, 2 POSITION
5	760-010-219	CRIMP TERMINAL, MALE, 14-20 AWG

